

RTS Series Package 06

Side load wood door and aluminum frame

Installation instructions

08280271 – 02-2020

| EN |

dormakaba 

Table of contents

1	Installation instructions	3
1.1	Prepare frame and install closer	3
1.2	Prepare top of door and install closer arm	4
1.3	Prepare bottom of door, install arm and floor bearing	5
1.4	Install door	6
2	Adjustments	7
2.1	Door alignment	7
2.2	Clearance requirements	7
2.3	Adjust closing speeds	8
3	Door removal	8

1 Installation instructions

1.1 Prepare frame and install closer

Fig.1

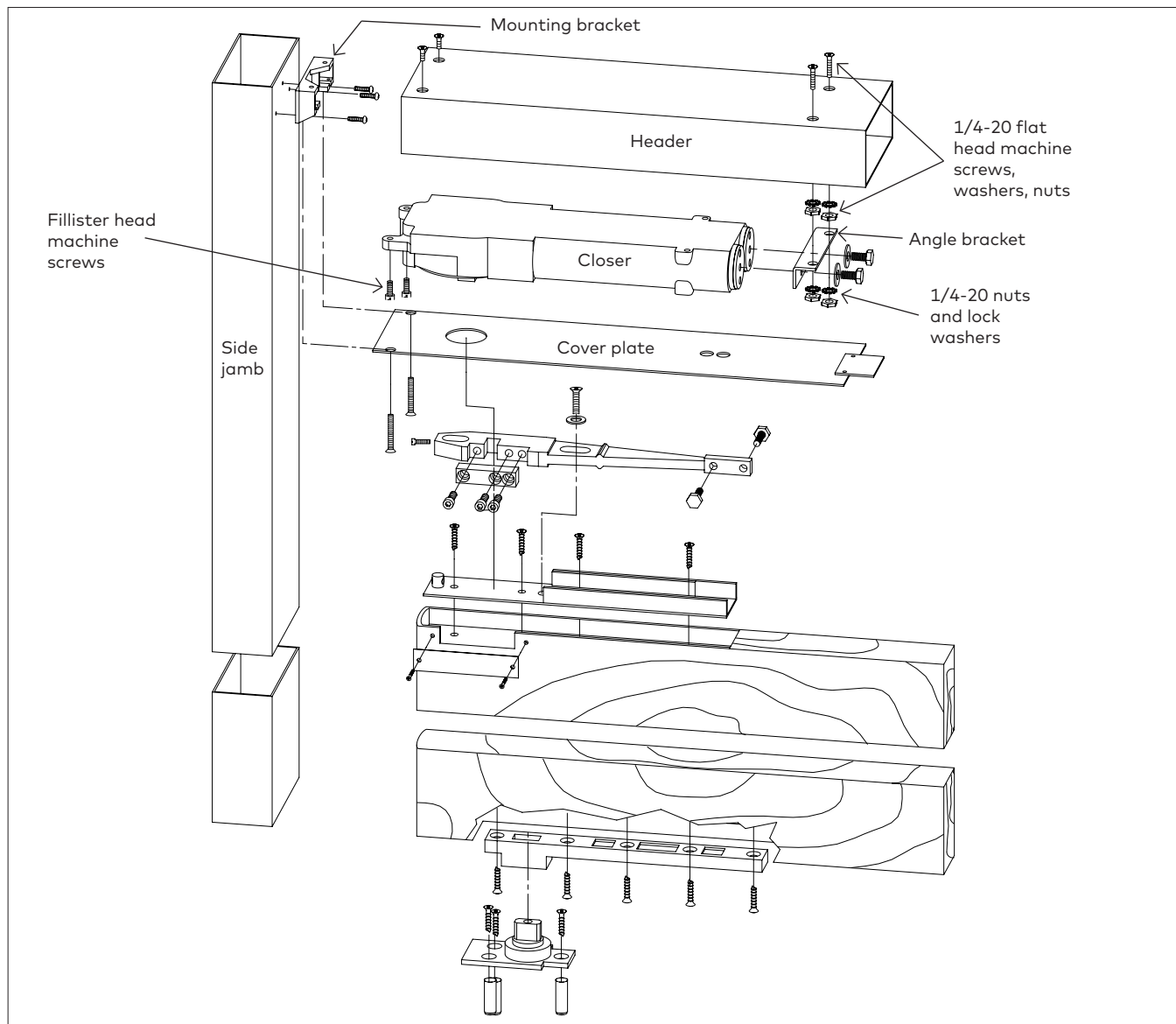

- 1.1.1 Prepare header and side jamb according to template.
- 1.1.2 Fasten mounting bracket to side jamb with three No. 8-32 pan head machine screws.
- 1.1.3 Fasten header to side jamb with two No. 10-32 flat head machine screws.
- 1.1.4 Fasten two 1/4-20 flat head machine screws to header with lock washers and nuts.
- 1.1.5 Fasten angle bracket to closer with 2 hex head machine screws and flat washers.
- 1.1.6 Install 2 fillister head machine screws into mounting tabs on closer.
- 1.1.7 Make approximately 3 turns.

NOTE: For RTS88 models only, do not remove spacer washers.

- 1.1.8 Install closer into header by inserting mounting tabs into mounting bracket.
- 1.1.9 Raise end of closer with angle bracket onto the two 1/4-20 screws.
- 1.1.10 Fasten angle bracket with the two remaining 1/4-20 nuts and lock washers.
- 1.1.11 Tighten the two fillister machine screws. **TIGHTEN SECURELY!**
- 1.1.12 Install cover plate by sliding tab into frame.
- 1.1.13 Fasten opposite end to mounting bracket with two No. 8-32 flat head machine screw provided.

1.2 Prepare top of door and install closer arm

Fig.2

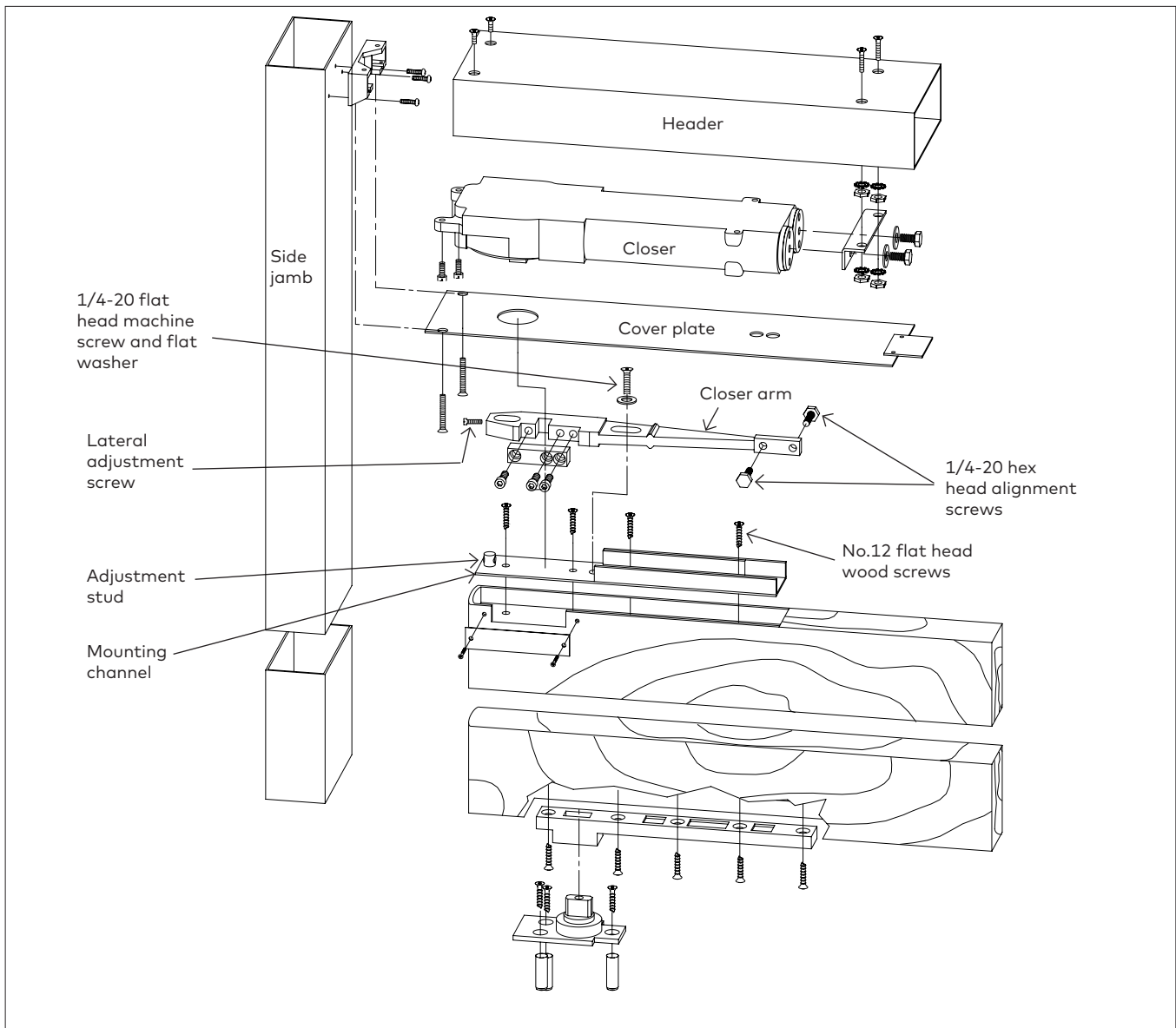

1.2.1 Prepare top of door according to template.

NOTE: Cut-out side of door should face interior of building.

1.2.2 Fasten 8832 mounting channel to door with four No. 12 flat head wood screws.

1.2.3 Install two 1/4-20 hex head alignment screws into closer arm.

1.2.4 Place arm over adjustment stud in arm channel.

1.2.5 Center arm in door, turning both 1/4-20 hex head alignment screws counter-clockwise until they are wedged against door channel.

1.2.6 Thread lateral adjustment screw into adjustment stud on 8832 mounting channel.

1.2.7 Secure arm into place with 1/4-20 flat head machine screw and flat washer.

1.3 Prepare bottom of door, install arm and floor bearing

Fig.3

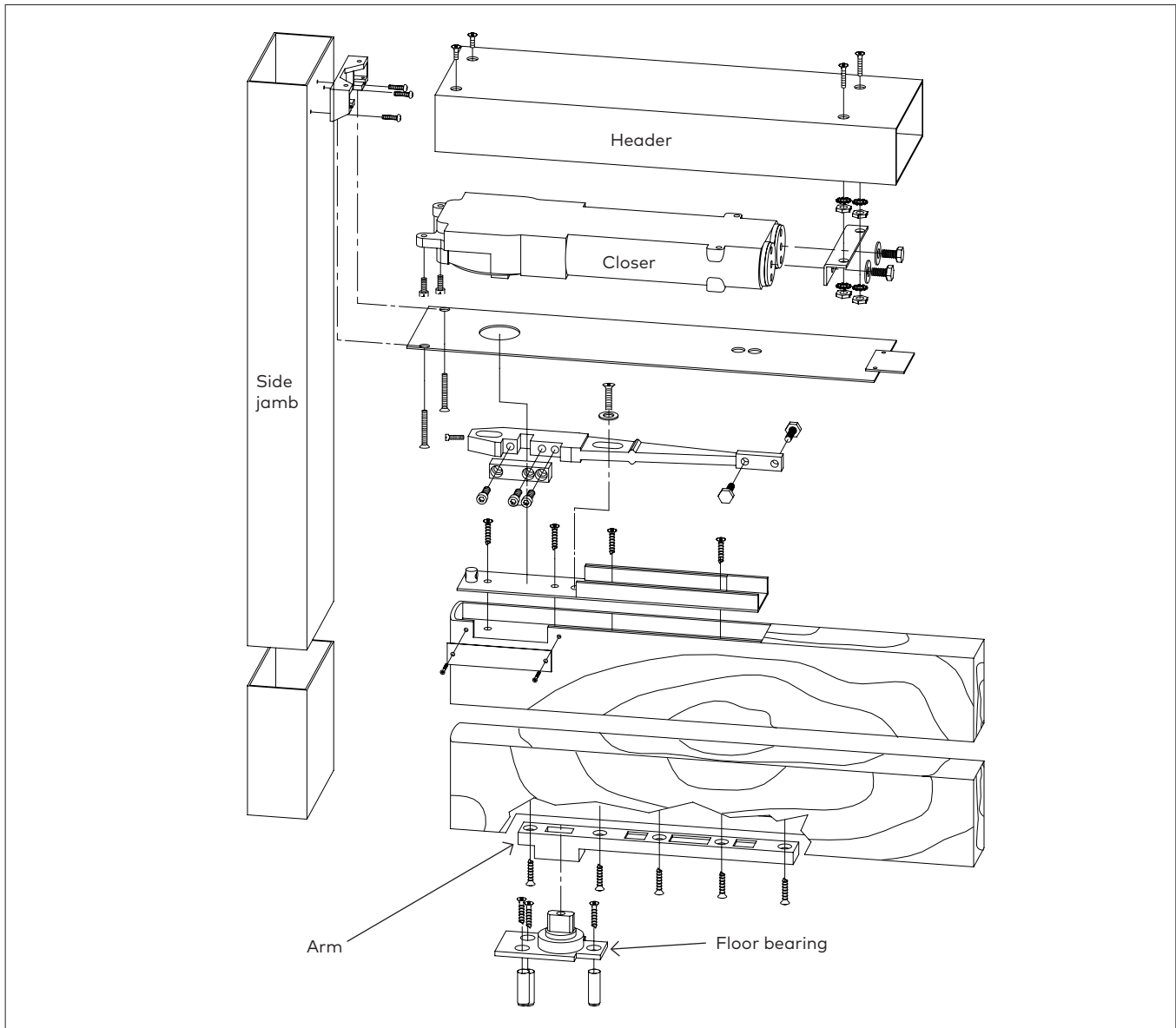

- 1.3.1 Prepare bottom of door according to template.
- 1.3.2 Fasten arm to door with five No. 14 flat head wood screws.

- 1.3.3 Prepare floor according to template.
- 1.3.4 Fasten floor bearing with three flat head wood screws and plastic anchors.
- **Optional: see template for threshold preparation.**

1.4 Install door

Fig.4

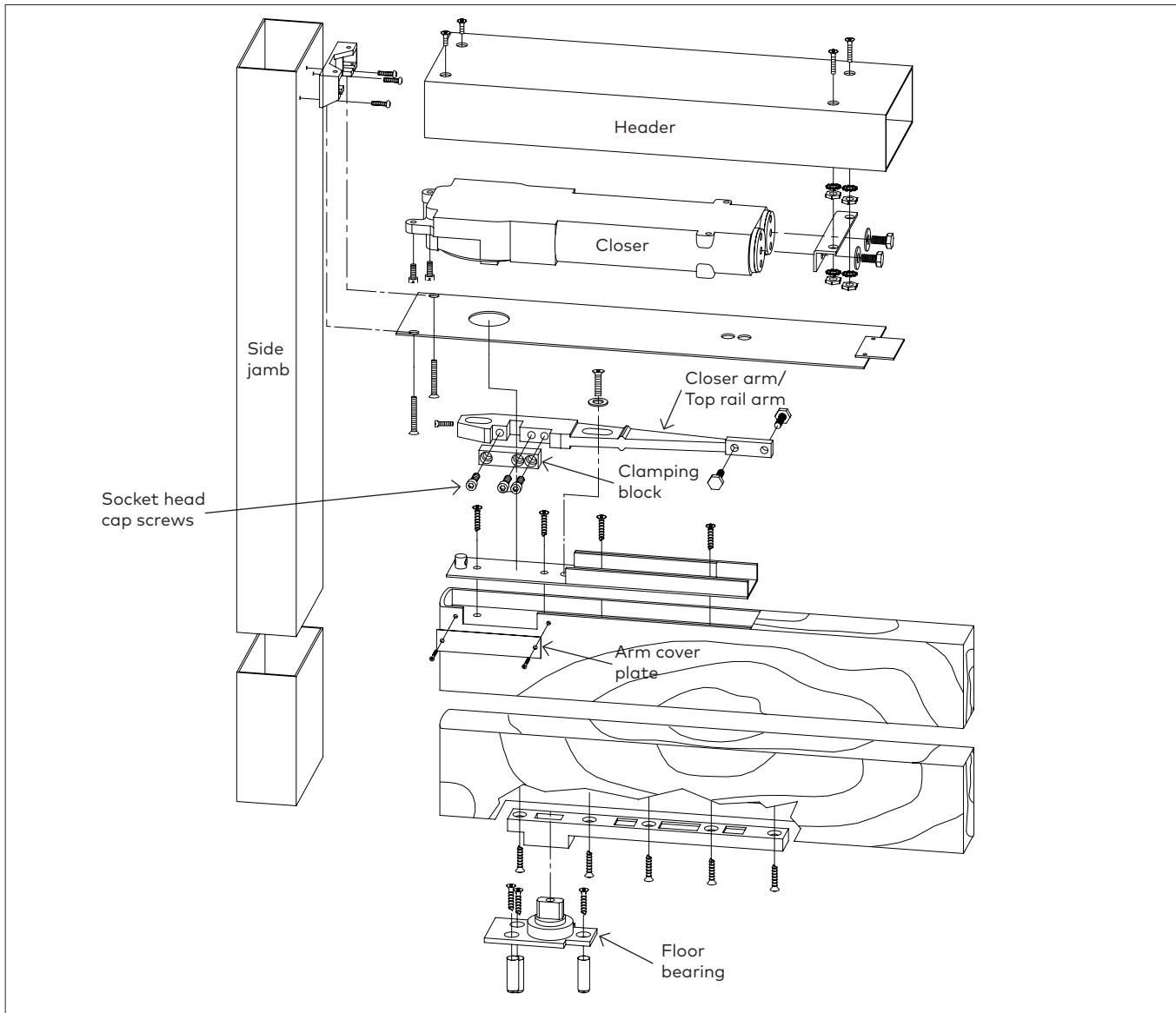

- 1.4.1 With door parallel to opening, place bottom of door onto floor bearing.
- 1.4.2 Push door to vertical position until closer spindle is completely engaged into closer arm.

- 1.4.3 Fasten clamping block to arm with three 1/4-20 socket head cap screws.

NOTE: Alternate fastening screws when tightening clamping block. TIGHTEN SECURELY!

- 1.4.4 Fasten arm cover plate to door with screws provided.

2 Adjustments

2.1 Door alignment

Fig.5

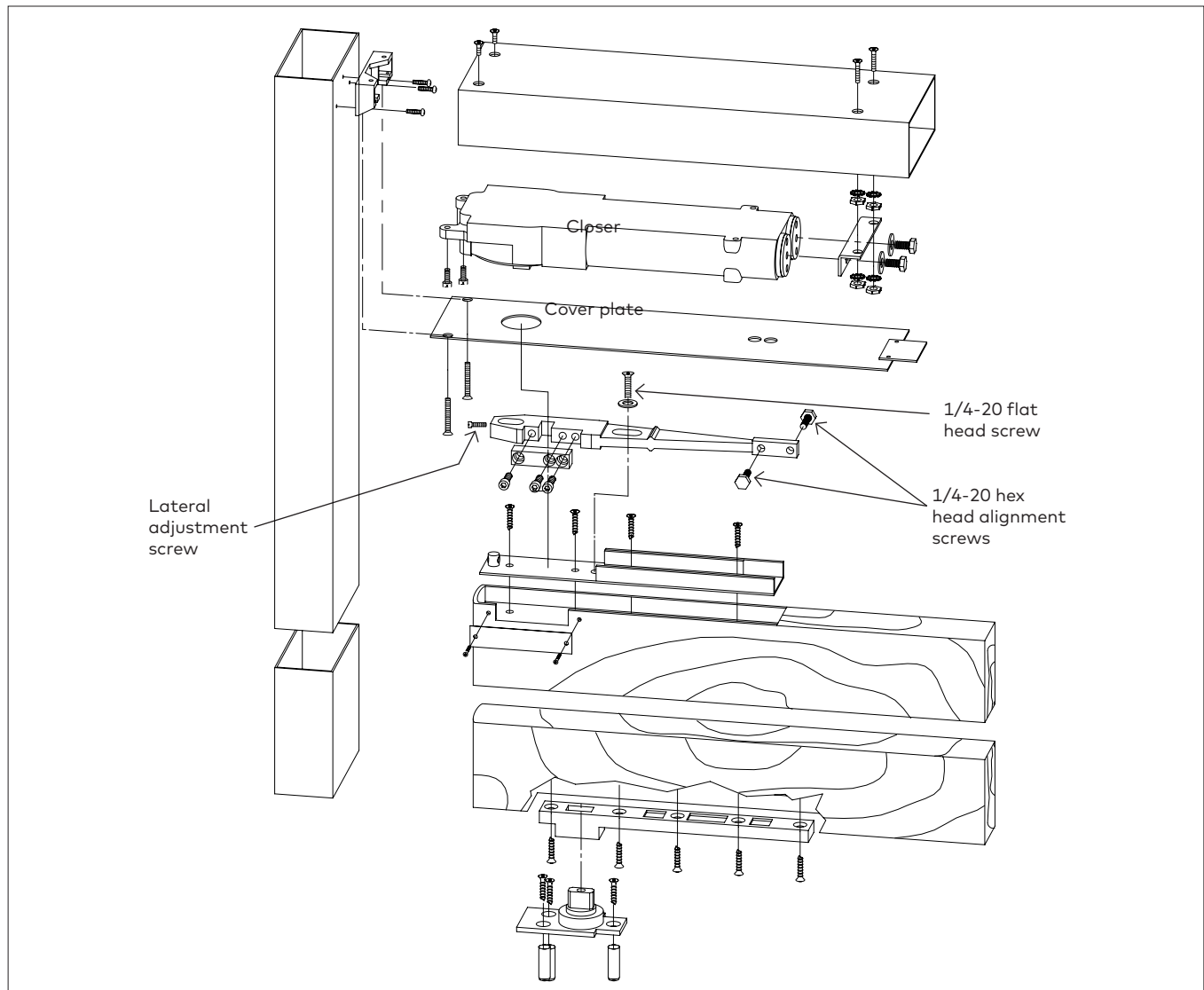

2.1.1 Double acting -

- Center door in frame by loosening 1/4-20 flat head screw and adjusting the two 1/4-20 hex head alignment screws as required.
- To adjust clearance between door and frame, adjust lateral adjustment screw.
- Retighten 1/4-20 flat head screw.
- TIGHTEN SECURELY!

2.1.2 Single acting -

- Adjust arm to insure that door closes tightly against stop.
- Loosen 1/4-20 flat head screw.
- Adjust closer arm fully in the direction of door swing.
- To adjust clearance between door and frame, adjust lateral adjustment screw.
- Retighten 1/4-20 flat head screw.
- TIGHTEN SECURELY!

2.2 Clearance requirements

Fig.6

<p>2.2.1 The standard spindle for 7471K will achieve a door clearance of 11/16" measured from finished floor to bottom of door.</p>	<p>2.2.2 See chart on template for optional spindles and door clearances.</p>
---	---

2.3 Adjust closing speeds

Fig.7

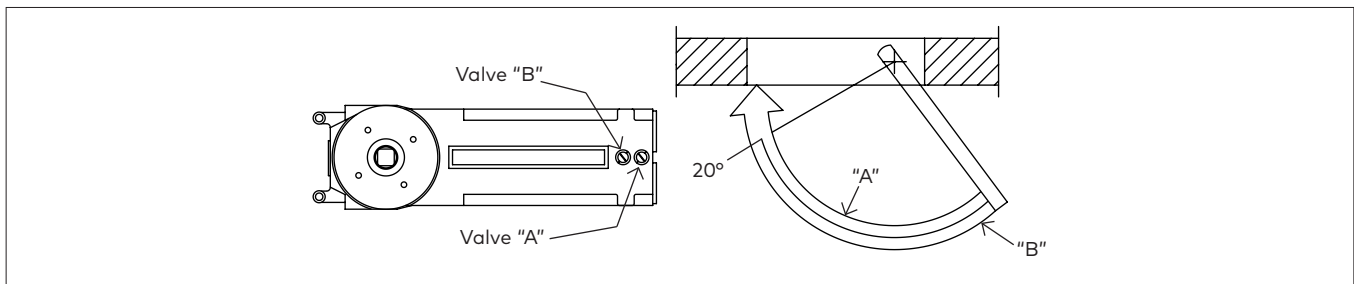

2.3.1 Valve "A" - controls closing speed from maximum opening angle to 0°.

- Clockwise - decreases closing speed
- Counter-clockwise - increases closing speed

2.3.2 Valve "B" - increases closing speed from maximum opening angle to 20°.

Counter-clockwise - increases closing speed.

3 Door removal

Fig.8

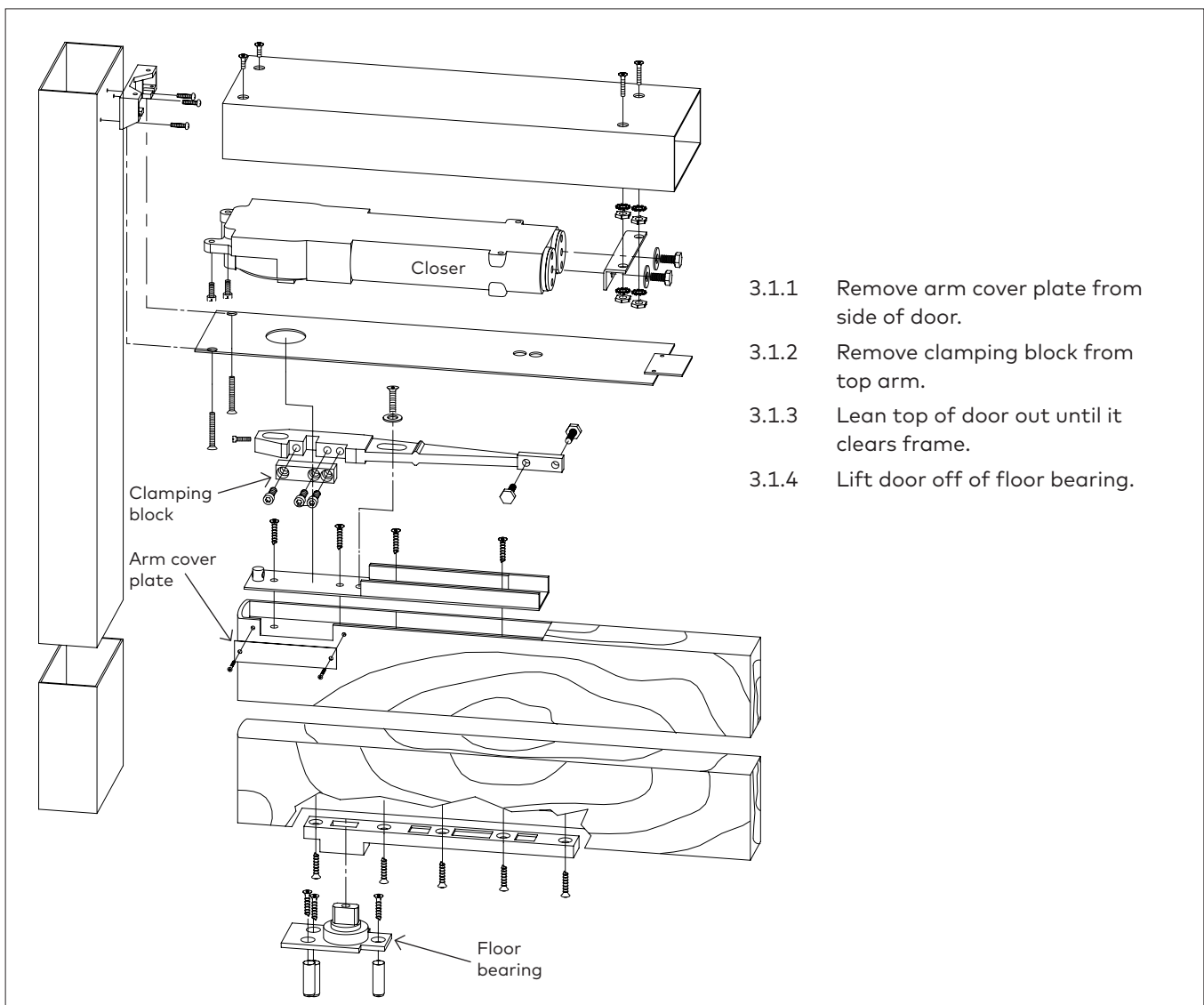

3.1.1 Remove arm cover plate from side of door.

3.1.2 Remove clamping block from top arm.

3.1.3 Lean top of door out until it clears frame.

3.1.4 Lift door off of floor bearing.

